

Adaptive GPC structures for temperature and relative humidity control of a nonlinear passive air conditioning unit, *Frontiers*

Rousseau Tawegoum, R. Riadi, A. Rachid, Gérard Chasseriaux

► **To cite this version:**

Rousseau Tawegoum, R. Riadi, A. Rachid, Gérard Chasseriaux. Adaptive GPC structures for temperature and relative humidity control of a nonlinear passive air conditioning unit, *Frontiers*. Edition ITECH, pp.201-220, 2008. <hal-00729094>

HAL Id: hal-00729094

<https://hal-agrocampus-ouest.archives-ouvertes.fr/hal-00729094>

Submitted on 20 Dec 2012

HAL is a multi-disciplinary open access archive for the deposit and dissemination of scientific research documents, whether they are published or not. The documents may come from teaching and research institutions in France or abroad, or from public or private research centers.

L'archive ouverte pluridisciplinaire **HAL**, est destinée au dépôt et à la diffusion de documents scientifiques de niveau recherche, publiés ou non, émanant des établissements d'enseignement et de recherche français ou étrangers, des laboratoires publics ou privés.

Adaptive GPC Structures for Temperature and Relative Humidity Control of a Nonlinear Passive Air Conditioning Unit

Rousseau TAWEGOUM¹, Riad RIADI¹, Ahmed RACHID², Gérard CHASSERIAUX¹.

¹*Unité Propre EPHOR(Environnement Physique de la plante HORTicole)
Institut National d'Horticulture 2, rue Le Nôtre 49045 Angers*

²*Université de Picardie Jules Verne, IUP GEII. 33, rue Saint LEU 80000 Amiens
FRANCE*

1. Introduction

The use of climate-controlled greenhouses and growth chambers makes it possible to maintain high crop productivity and quality when outside air conditions are not favourable. Climate control accuracy may help optimize production costs by reducing energy consumption and by better respecting production calendars. Such objectives can be reached by incorporating new technologies for crop growth chambers and reduced greenhouses with an HVAC installation. Various climate control technologies have been used for commercial and experimental greenhouses and growth chambers. Many studies have focused mainly on temperature control, while considering relative humidity to be of secondary importance, a background detail.

Generally speaking, air conditioning units used in crop growth chambers are made up of heating and cooling system components with a compression cycle (Hanan, 1997; Arquello & Velez, 1999; Jones & Jones, 1984). In addition to the energy cost and the high maintenance expenses for this type of system, they present an ecological issue due to the pollutant emissions generated by the use of refrigerating gases.

The main cooling technologies routinely used in greenhouses are ventilation, evaporative cooling, and composite systems. A simple way to reduce the difference between inside and outside air temperature is to improve ventilation. Natural ventilation uses very little external energy, but whether it is natural or forced, ventilation is of limited efficiency and not satisfactory on sunny days.

Evaporative cooling using fan-pads (Kittas et al., 2003) or fog/mist (Montero et al., 1994) inside greenhouse and roof cooling systems (Willits & Peet, 2000) represents an efficient means of greenhouse cooling that can lower the inside air temperature significantly below the ambient air, but the range of relative humidity variation remains limited. Fan-pads work on negative pressure, so that very often outside hot air mixes with the inside cool air through infiltration, which reduces the efficiency of the system quite significantly. Mist or

fog systems can provide more uniform temperature distribution than fan-pad systems, in addition to ensuring uniform high humidity levels. One of the drawbacks of fog mist is that the compressor consumes large amounts of energy, which increases the cost of operating the system. This method also uses expensive foggers or nozzles, which often shocked due to insoluble and soluble salt present in the water, thereby reducing the working efficiency of the system.

Apart from these systems, two primary composite systems, such as earth-to-air heat exchangers (EAHES) and aquifer coupled cavity flow heat exchangers (ACCFHES), can be used for heating as well as cooling greenhouses. The EAHES uses the earth potential for heating and the ground potential of the earth for cooling the greenhouses in summer conditions due to its constant year round temperature. In this case, hot greenhouse air is circulated through the buried pipe (2-4m depth) for dissipation of heat to the underground soil. The aquifer coupled cavity flow heat exchanger system (Sharma 2007a) uses deep underground aquifer water from an irrigation tube well at the ground surface at nearly constant temperature. The major disadvantage of using EAHES is the cost of digging and laying the pipes. Deterioration of the pipes under soil pressure also makes this system less reliable for projects of long duration. A substantial review of cooling technologies may be found in (Sethi & Sharma 2007).

We have investigated an ecological approach for climate control based on a passive principle. A similar approach is set out in (Buchholz et al., 2006). The conditioning unit under study is a new design with innovative proprieties and offers various environmental advantages (Tawegoum *et al.*, 2006a). It does not use the more typical compression system or absorption-refrigeration cycle. It was designed to produce a microclimate with variable temperatures and variable relative humidity setpoint values inside the growth chambers. A complete physical model of this plant developed in (Riadi *et al.*, 2006) shows that this complex global system is composed of three nonlinear subsystems.

In this chapter, the adaptive direct and indirect general predictive control is used to control the temperature and the relative humidity produced by the passive air conditioning unit. The chapter is divided into three sections. The first section is devoted to the analytical modelling of a conditioning unit. The second defines the properties of adaptive direct and indirect approaches used for control. The last section presents real time results from the system.

2. Analytical model of the system

2.1 System description

The required micro-climate must be produced by a passive air-conditioning system without a freezing unit and compressor, or refrigeration cycle, and without pollutant emissions (Tawegoum et al., 2006a). The specificity of this system is tied to its capacity to produce a variable microclimate with variable temperatures and relative humidity set points. Since temperature and relative humidity are highly coupled, one way to achieve these objectives is to delink the control of the temperature from the relative humidity control. The air-conditioning cycle is presented in the diagram below.

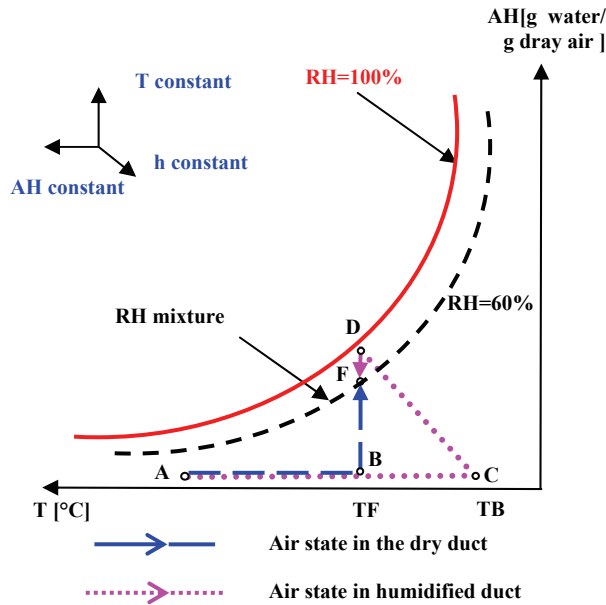

Fig. 1. Thermodynamic cycle of the unit

Figure 1 shows the different thermodynamic phases of the air-conditioning cycle and the region corresponding to our zone of interest. The system depends on mixing two air flows, each with a different humidity level. The air intake can be from inside the greenhouse (point B) or outside the greenhouse (point A). Regardless of the source of the air supply, the characteristics of the air are clearly defined.

The characteristics of the air at point F are also known because the final temperature T_F is the set point temperature, and the moisture RH_F is set by the user. As the air heating operates at a constant absolute humidity, point B can be easily found by knowing the value T_F .

Computing the characteristics of the air at point C is more complex. These characteristics can be deduced from point D, at which the temperature equals T_F . In D, air must be practically saturated. As cooling humidification (from C to D) operates at constant enthalpy, point C can be calculated by determining the characteristics of points D and A.

The energy required for heating can be computed based on the enthalpy values of points A, B and C. The airflow rate required to obtain the relative humidity set point is computed using the relative evolution of the line 'D-B'. Considering the values of q_i , the final expressions of the absolute humidity (absolute moisture content) and the temperature are obtained by the following static thermodynamic equations:

$$AH_F = \frac{q_1 AH_B + q_2 AH_D}{q_1 + q_2} \quad (1)$$

$$T_F = \frac{q_1 (\alpha + \beta AH_B) T_B + q_2 (\alpha + \beta AH_D) T_D}{q_1 (\alpha + \beta AH_B) + q_2 (\alpha + \beta AH_D)} \tag{2}$$

with $\alpha = 0.24$, $\beta = 0.46$ and q_i being the air flow mass proportional to the aperture position. Knowing both AH_F and T_F gives a unique value of RH_F (Tawegoum et al., 2006a).

The unit is composed of two flows: a non-saturated flow (or dry duct) and a saturated flow (or humidified duct). As shown in figure 2, in the saturated air flow, fresh air is saturated in humidity after being heated by a coil resistor. Saturation operates at constant enthalpy (Chraïbi et al., 1995). The saturation unit consists of a closed system, including a pump, a water tank and cross-corrugated cellulosic pads of the type used in cooling. The suction pump carries water from the tank to the top of the pads. Once a steady state of saturation is reached, the pads contain a constant mass of water with a given water output rate and a given temperature. In the unsaturated air flow, fresh air is only heated by another resistor coil. Dry pads are included to provide pressure drop balance. The low speed of the air and the water through the pads reduces the difference in pressure drop between the two streams.

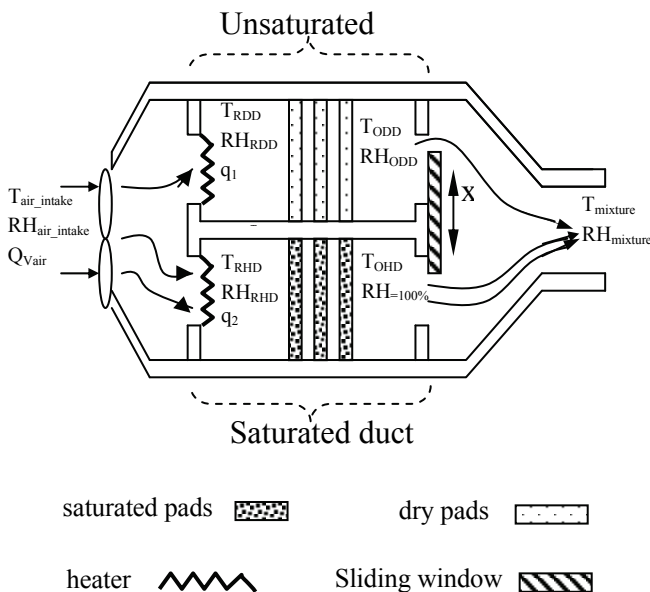

Fig. 2. Air-conditioning system

The proportional mixing of the two air flows is carried out by an aperture operate by a DC motor. Assuming that the two air flows are mixed properly, a local climate can be easily produced in the growth chamber.

2.2 System modelling

2.2.1 Temperature modelling

The differential equations describing the dynamic behaviour of the conditioning unit are derived from the energy conservation law. The temperature behaviour in the mixing zone is given by:

$$\frac{dT_{\text{mixture}}}{dt} = -\frac{\alpha(x)Q_{\text{Vair}}}{V_{\text{mixer}}}[T_{\text{mixture}} - T_{\text{ODD}}] - \frac{(1 - \alpha(x))Q_{\text{Vair}}}{V_{\text{mixer}}}[T_{\text{mixture}} - T_{\text{OHD}}] \quad (3)$$

where T_{mixture} is the air temperature (°C) in the mixer, T_{ODD} is the air temperature (°C) after the dry duct, T_{OHD} is the air temperature (°C) after the humidified duct, $a(x) \in [0,1]$ the volumetric air flow percentage in the dry duct (%), x the percentage of aperture opening (%), Q_{Vair} the total volumetric air flow rate (m³/s), V_{mixer} the volume of the air mixer.

q_1, q_2 are the volumetric air flow rates depending on the aperture position (figure 2). The total volumetric air flow rate Q_{Vair} is given as:

$$Q_{\text{Vair}} = q_1 + q_2 = \alpha(x)Q_{\text{Vair}} + (1 - \alpha(x))Q_{\text{Vair}} \quad (4)$$

In the dry duct, the heat balance in the pads is expressed by the following equation:

$$\frac{dT_{\text{ODD}}}{dt} = -\frac{\alpha(x)Q_{\text{Vair}}}{V_{\text{DD}}}[T_{\text{ODD}} - T_{\text{air_intake}}] + \frac{k_{\text{RDD}}}{\rho_{\text{air}} C_{\text{air}} V_{\text{DD}}} U_{\text{DD}} \quad (5)$$

with $T_{\text{air_intake}}$ the intake air temperature (°C), U_{DD} the applied voltage (V), proportional to the resistor heating in the dry duct, k_{RDD} the proportional coefficient between the voltage and the heating-power (J/sV), ρ_{air} the air density (kg/m³), C_{air} the specific heat of air (J/kg °C), V_{DD} the volume of the dry duct (m³).

In the humidified duct, the heat balance in the pads and the heater lead to the following equations:

$$\begin{aligned} \frac{dT_{\text{OHD}}}{dt} = & -\frac{(1 - \alpha(x))Q_{\text{Vair}}}{V_{\text{pad}}}[T_{\text{OHD}} - T_{\text{RHD}}] - \frac{h A_{\text{pad}}}{\rho_{\text{air}} C_{\text{air}} V_{\text{pad}}}[T_{\text{RHD}} - T_{\text{wat_intake}}] \\ & + L_v(T_{\text{wat_intake}}) \frac{(1 - \alpha(x))Q_{\text{Vair}}}{C_{\text{air}} V_{\text{pad}}} + [AH_{\text{sat}}(T_{\text{wat_intake}}) - AH_{\text{air_intake}}] \end{aligned} \quad (6)$$

where T_{RHD} is the air temperature (°C) after the heater of the humidified duct, $T_{\text{wat_intake}}$ the intake water temperature in the pads of the humidified duct, U_{HD} the applied voltage

(V), proportional to the heating in the humidified duct, $AH_{\text{sat}}(T_{\text{wat_intake}})$ and $AH_{\text{air_intake}}$ are respectively the saturated absolute humidity at the temperature of water intake and the absolute humidity of the air intake (kg of water/kg of dry air), k_{RHD} the proportional coefficient between the voltage and the heating-power (J/sV), ρ_{water} the water density (kg/m³), C_{water} the water specific heat (J/kg °C), V_{RHD} the heater chamber volume of the humidified duct (m³), V_{pad} the pads volume (m³), A_{pad} the pads exchange area (m²), $L_V(T_{\text{wat_intake}})$ latent heat (J/kg of water) at the temperature of the intake water, h the convective heat coefficient (J/m²s°C) .

2.2.2 Relative humidity modelling

The heat and mass conservative law applied to the humid duct, the dry duct and the mixing zone give rise to the following equations for absolute humidity.

$$\begin{aligned} \frac{dAH_{\text{OHD}}}{dt} = & -\frac{(1-\alpha(x))Q_{V\text{air}}}{\varepsilon_r V_{\text{pad}}} [AH_{\text{OHD}} - AH_{\text{air_intake}}] \\ & + \frac{1}{\rho_{\text{air}} C_{\text{air}} \varepsilon_r V_{\text{pad}}} [Q_{\text{wat_intake}} - Q_{\text{wat_outake}}] \end{aligned} \quad (7)$$

$$\begin{aligned} \frac{dAH_{\text{mixture}}}{dt} = & -\frac{\alpha(x)Q_{V\text{air}}}{V_{\text{mixture}}} [AH_{\text{mixture}} - AH_{\text{ODD}}] \\ & + \frac{(1-\alpha(x))Q_{V\text{air}}}{V_{\text{mixture}}} [AH_{\text{mixture}} - AH_{\text{OHD}}] \end{aligned} \quad (8)$$

where ε_r is the pad porosity coefficient (%), $Q_{\text{wat_intake}}$ is the water intake flow mass (Kg/s). More detailed information may be found in (Riadi, 2007).

The physical models shown above are complex and difficult to use for control objectives, especially with respect to relative humidity. The model structure is MIMO, with internal coupling between the temperature and relative humidity, and an instationarity due to the operating point variation during the control (Riadi et al., 2007). Mention can also be made of the presence of the external disturbance on the controlled outputs (temperature, relative humidity). The air flow measurements for the main aperture positions indicate a nonlinear relationship between the percentage of air flow and the percentage of aperture positions (Tawegoum et al., 2006b).

To take into account these uncertainties and complexities, the process is seen as a time-varying system and the recursive estimation approach must be used to estimate parameters in real time. The predictive control algorithms based on generalized predictive control or even long range predictive control strategies have proven to be efficient, flexible and

successful for industrial applications (Corréa et al., 2000; Nybrant, 1989; Rafilamanana et al., 1992). This strategy is associated with the recursive estimation algorithm in order to obtain better performance for both tracking and regulation problems.

3. Indirect and Direct Generalized Predictive Control (GPC) design

3.1 Indirect Generalized Predictive Control concepts

The synthesis of the generalized predictive controller (GPC) suggested by Clarke (Clarke et al., 1987a; Clarke et al., 1987b) provides one of the methods that may be used as an adaptive control strategy. However, it must be combined with an online identification method (Landau & Dugard, 1986; Msaad & Chebassier, 1992). This method was used successfully in industrial applications of various forms (Dumur et al., 1997; Richalet et al., 1978; Filatov & Unbedhauen, 2004; Dion et al.1991.). Among the declared advantages of the generalized predictive control (Clarke, 1988; Camacho & Bordons, 2000), one may mention that it can be applied to processes with variable pure delay, with a non-minimum phase, and that it does not involve an apparent problem when the process model has too many parameters, contrary to pole placement strategies and linear quadratic control.

The method described in this paragraph is developed by Clarke (Clarke et al., 1987a), (Clarke et al., 1987b), and is given in the SISO case :

1) The basic model is CARIMA (Controlled Auto-Regressive Integrated Moving Average) defined to represent the behaviour of the process around a nominal operating point, given by the following form:

$$A(q^{-1})\Delta y(k) = B(q^{-1})\Delta u(k-d) + C(q^{-1})\varepsilon(k) \quad (9)$$

$y(k)$ is the system output, $u(k)$ the system input, $\varepsilon(k)$ the uncorrelated random sequence, $\Delta(q^{-1}) = 1 - q^{-1}$ the difference operator, $A(q^{-1}), B(q^{-1}), C(q^{-1})$, are polynomials with n_a, n_b and n_c degree respectively.

2) The optimal j -step ahead prediction of the system output using the available information at instant ' k ', is given by (10):

$$\hat{y}(k+j) = G_j(q^{-1})\Delta u(k+j-1) + I_j \quad (10)$$

where: $I_j = F_j(q^{-1})y(k) + H_j(q^{-1})\Delta u(k-1)$

Where: F_j, E_j, G_j, H_j are polynomial solutions to the Diophantine equations.

the matrix formulation is represented in (11):

$$\hat{Y} = G.\Delta U + L \quad (11)$$

with

$$\hat{Y}^T = [\hat{y}(k+1) \dots \hat{y}(k+N_2)]; \Delta U^T = [\Delta u(k) \dots \Delta u(k+N_2-1)]; L^T = [l_1(k+1) \dots l_{N_2}(k+N_2)]$$

3) The performance index is a weighted sum of predicted tracking errors and future control signal increments:

$$J(k) = \sum_{j=N_1}^{N_2} (w(t+j) - \hat{y}(k+j))^2 + \lambda \sum_{j=N_1}^{N_2} (\Delta u(k+j-1))^2 \quad (12)$$

where: $\Delta u_j(k+j) = 0$, for $j \geq N_u$.

$w(k+j)$ are the set points values at time $k+j$, $\hat{y}(k+j)$ the output prediction at time $k+j$, N_1 the minimum prediction horizon, N_2 the maximum prediction horizon, N_u the control horizon, λ the control-weighting factor.

4) A closed form solution of the optimal law exists, which takes as inputs $y(k)$ and $u(k-1)$ and as output ΔU_{opt} [13]. The formula is derived through analytical minimization of the previous cost function. The optimal control law is:

$$\Delta U_{opt} = \left[G^T G + \lambda I \right]^{-1} G^T (W - L) \quad (13)$$

With G a $(N_2 - N_1 + 1) \times N_u$ matrix. Only the first control value is finally applied to the system according to the receding horizon strategy:

$$u_{opt}(k) = u_{opt}(k-1) + \bar{G}(W - L) \quad (14)$$

where \bar{G} is the first line of matrix $\left[G^T G + \lambda I \right]^{-1} G^T$.

The equivalent RST controller is computed through a difference equation [17]:

$$S(q^{-1})u(k) = T(q^{-1})w(k+N_2) - R(q^{-1})y(k) \quad (15)$$

In the case of time varying parameters, the previous controller must be included within an adaptive structure. The system parameters $A(\hat{a}, q^{-1})$, $B(\hat{a}, q^{-1})$ are estimated in real time and indirectly. The GPC controller parameters $S(\hat{a}, \hat{b}, q^{-1})$, $R(\hat{a}, \hat{b}, q^{-1})$, $T(\hat{a}, \hat{b}, q^{-1})$ are updated (Ljung, 1999), using the well known least square algorithm with a fixed forgetting factor so as to ensure the closed loop stability and the desired performance (Msaad & Chebassier, 1992), (Bitmeat et al., 1990).

3.2 Direct Generalized Predictive Control concepts

A direct adaptive GPC, based on the work of (Wang & Henrisken, 1993), (Wang & Henrisken, 1994) is used with a direct identification of the controller parameters. In this approach, the GPC algorithm is included in an adaptive framework considering a direct scheme, directly updating the controller parameters. This strategy makes it necessary first to reformulate the polynomial GPC controller in adequate form.

3.2.1 Some basic GPC notations

For the Direct adaptive case, the prediction vector (10) is rewritten in the following form:

$$\hat{y} = \mathbf{G}\tilde{\mathbf{u}} + \mathbf{if} y(t) + \mathbf{ih} \Delta u(t - 1) \tag{16}$$

The minimization of the Eq.(12) written in a matrix form provides from the future control sequence:

$$\tilde{\mathbf{u}} = \mathbf{M}[\mathbf{w} - \mathbf{if} y(t) - \mathbf{ih} \Delta u(t - 1)] \tag{17}$$

With: $\mathbf{if} = [F_{N_1}(q^{-1}) \dots F_{N_2}(q^{-1})]^T$; $\mathbf{ih} = [H_{N_1}(q^{-1}) \dots H_{N_2}(q^{-1})]^T$
 $\tilde{\mathbf{u}} = [\Delta u(t) \dots \Delta u(t + N_u - 1)]^T$; $\hat{\mathbf{y}} = [\hat{y}(t + N_1) \dots \hat{y}(t + N_2)]^T$
 $\mathbf{w} = [w(t + N_1) \dots w(t + N_2)]^T$

$$\mathbf{G} = \begin{bmatrix} g_{N_1}^{N_1} & g_{N_1-1}^{N_1} & \dots & \dots \\ g_{N_1}^{N_1} & g_{N_1}^{N_1+1} & \dots & \dots \\ \dots & \dots & \dots & \dots \\ g_{N_2}^{N_2} & g_{N_2-1}^{N_2} & \dots & g_{N_2-N_u+1}^{N_2} \end{bmatrix}$$

$$\mathbf{M} = [\mathbf{G}^T \mathbf{G} + \lambda \mathbf{I}_{N_u}]^{-1} \mathbf{G}^T \text{ of dimension } (N_2 - N_1 + 1) \times N_u$$

The GPC controller is implemented under a RST form through difference equation:

$$S(q^{-1})\Delta u(t) = T(q^{-1})w(t) - R(q^{-1})y(t) \tag{18}$$

With: $S(q^{-1}) = 1 + \mathbf{m}_1 \mathbf{ih} q^{-1}$, $R(q^{-1}) = \mathbf{m}_1 \mathbf{if} q^{-1}$, $T(q^{-1}) = \mathbf{m}_1 [q^{N_1} \dots q^{N_2}]$.

3.2.2 Reformulation as performance index

A- Definition of the performance error.

Consider first the following regressor:

$$\Phi(t) = [y(t) \dots y(t - n_a) \tilde{u} \Delta u(t - 1) \dots \Delta u(t - n_b)]^T \quad (19)$$

With $\Phi(t)$ of dimension $(n_a + n_b + N_u + 1)$, and θ the parameter matrix:

$$\theta = [M \text{ if } I_u \ M \text{ ih}]^T \quad (20)$$

The control law (17) stems from the new matrix form:

$$Mw = \theta^T \Phi(t) \quad (21)$$

Let us now introduce the following predictive vector (predicted outputs between the horizons N_1 and N_2 and future control values up to horizon N_u):

$$X(t + N_2) = [\hat{y} \quad \tilde{u}]^T \quad (22)$$

and the vector Xw , of the same dimension $(N_2 - N_1 + N_u + 1)$, called target Vector. Considering the fact that the output vector \hat{y} has to converge to the reference vector w while the control signal \tilde{u} has to tend to zero, Xw is defined by:

$$Xw(t + N_2) = [w \quad 0]^T \quad (23)$$

Finally, a weighting matrix L is defined to create a cancellation dynamics of performance error so that the filtered error is the following:

$$e_f(t + N_2) = iP(t + N_2) - iPw(t + N_2) = L^T [X(t + N_2) - Xw(t + N_2)] = L^T e \quad (24)$$

With these definitions, $iP(t + N_2)$ is an indication of the measured performances and $iPw(t + N_2)$ an evaluation of the expected performances.

B- Performance index.

The performance index to be minimized is quadratic cost function \mathfrak{J} defined by:

$$\mathfrak{J}(t + N_2) = e_f(t + N_2)^T e_f(t + N_2) = [X(t + N) - Xw(t + N)]^T L L [X(t + N) - Xw(t + N)] \quad (25)$$

From this, the objective in the adaptive case is to minimize this performance index \mathfrak{J} at each step, in order to reach asymptotically and without plant parameter knowledge:

$$\lim_{x \rightarrow \infty} e_f(t+1) = 0$$

Theorem

The fixed GPC control law explicitly cancels the performance index \mathfrak{J} considering the nominal model. The \mathbf{L} matrix is defined by:

$$\mathbf{L} = [\mathbf{M} \ \lambda]^T = [\mathbf{Q}_2 \ \mathbf{Q}_1]^T \tag{26}$$

Proof: See (Ramond et al., 1998).

Including the RST structure and the performance error, the DAGPC algorithm is represented in Fig.3

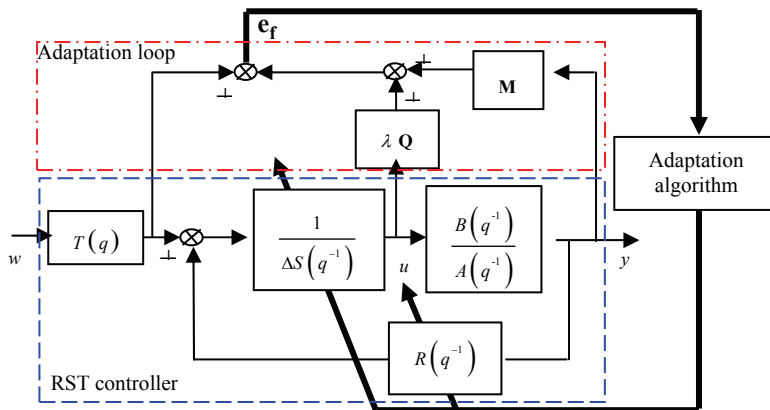

Fig. 3. Equivalent structure of the DAGPC

C- Least-squares identification

The previous section showed that the measured performances index is given by the relation:

$$i\mathbf{P}(t+N_2) = \mathbf{M}\hat{\mathbf{y}} + \lambda\mathbf{Q}\tilde{\mathbf{u}} \tag{27}$$

And the expected index by:

$$i\mathbf{P}\mathbf{w}(t+N_2) = \mathbf{M}\mathbf{w} = \theta^T\Phi(t) \tag{28}$$

For the time varying parameters, the fixed controller parameters matrix θ must be moved to an estimated matrix $\hat{\theta}(t)$ (see Astrom and Wittenmark, 1989; Isermann, et al., 1992) to ensure that the same criterion \mathfrak{J} always equals 0. The controller parameter matrix is updated according to a least squares-types method.

4. Real time results

For the Indirect or Direct strategy, the recursive identification and GPC code developed with Matlab® software were connected to the industrial automation via a local area network managed by interface developed with Delphi® software. A set of electronic units was used to apply heating voltage on the resistors or to control the DC motor and thus the Aperture opening rate. Measurements were performed using Pt100 sensors for temperature and encoder sensors for Aperture position. A sampling interval of $T_e=30$ seconds was chosen to satisfy the predominant time constant, and data acquisition time was about twelve hours. The operating point (aperture opening) values interval was $x \in [0\%, 100\%]$.

4.1 Indirect strategy

The different discrete models structure of the temperature of dry and humid ducts are given by:

$$\frac{T_{ODD}(k)}{U_{DD}(k)} = \frac{q^{-1}(b_{11}(k) + b_{12}(k)q^{-1})}{1 + a_{11}(k)q^{-1} + a_{12}(k)q^{-2} + a_{13}(k)q^{-3}} \quad (29)$$

$$\frac{T_{OHD}(k)}{U_{HD}(k)} = \frac{q^{-1}(b_{21}(k) + b_{22}(k)q^{-1})}{1 + a_{21}(k)q^{-1} + a_{22}(k)q^{-2} + a_{23}(k)q^{-3}} \quad (30)$$

Concerning the estimator algorithm, the models parameters were initialized by zero vectors and the covariance matrix $F(0) = 10^5$, with a fixed forgetting factor $\eta = 0.95$. In order to facilitate the convergence of the recursive estimation algorithm, a persistent sequence excitation (PRBS) was applied during the first 70 th sample times as can be seeing in figure 4 and figure 6, before running the generalized predictive control algorithm in real time. For the GPC algorithm controller, the control-weighting factor $\lambda = 0.97$, the minimum prediction horizon was fixed at a value $N_1 = d = 1$, and the maximum prediction horizon $N_2 = 14$, with a control horizon $N_u = 7$. Parameter variation is shown in figures 5 and 7. More detailed information may be found in (Riadi et al., 2007).

Generally speaking, control performance was good, as shown by the IAGPC for different setpoint values. The temperature ducts are closed to the setpoints in figures 4 and 6. The figures generally show an efficient disturbance rejection. These disturbances, caused by the intake air temperature, are eliminated by the integral action existing in the CARIMA basic model. The dry duct controller cancels parametric perturbation due to the abrupt and significant change of aperture position.

The control strategy robustness was also observed through temperature overshoot rejection. This type of disturbance is caused by the aperture commutation (operating point system variations) which in reality affects the air rate flow variation. At 700 th sampling time in figure 6, the overshoots presented by the humid duct air temperature response result from the abrupt aperture opening commutation, which introduces a parametric error estimation and, consequently, instantaneous closed loop instability between the 800 th and the 900 th

sampling time. These can be explained by the non-persistence of the control signal in a steady state, causing the cross-correlation of the covariance matrix vectors, which leads to the estimator divergence.

In figure 8, the air temperature fluctuations do not appear between the 800 th and the 900 th sample time, such as in figure 6, because during this window of time, the humid duct was nearly closed ($10% < x% < 18%$). As a result, its contribution to air mixing was reduced.

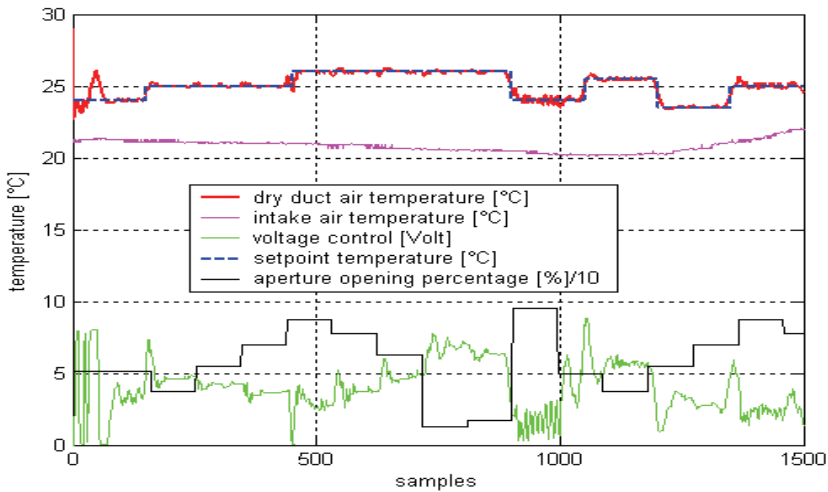

Fig. 4. IAGPC of the air dry duct temperature

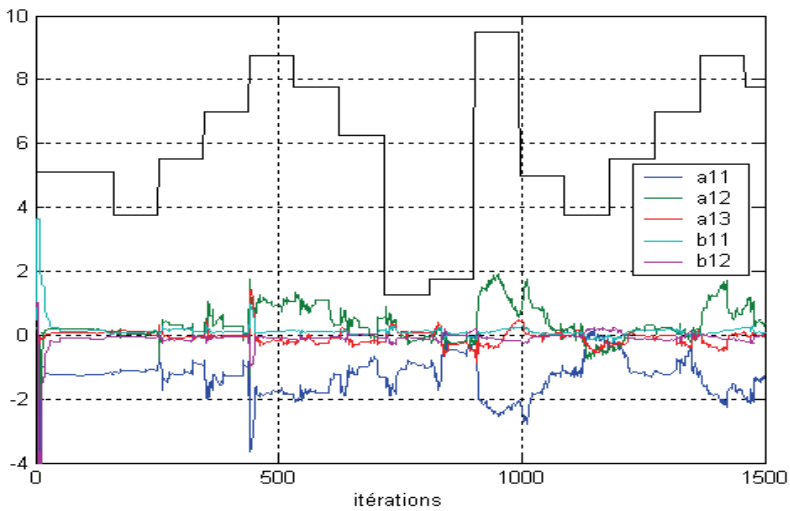

Fig. 5. Dry duct model estimated parameters

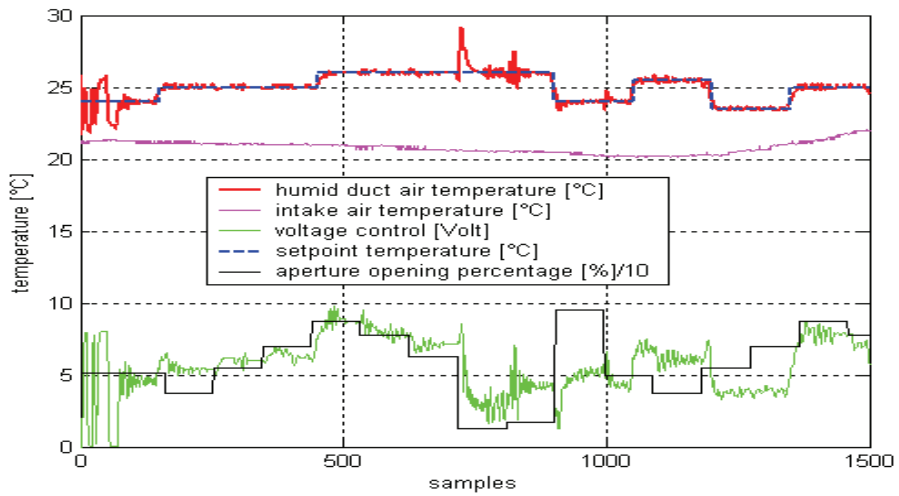

Fig. 6. IAGPC of the air humid duct temperature

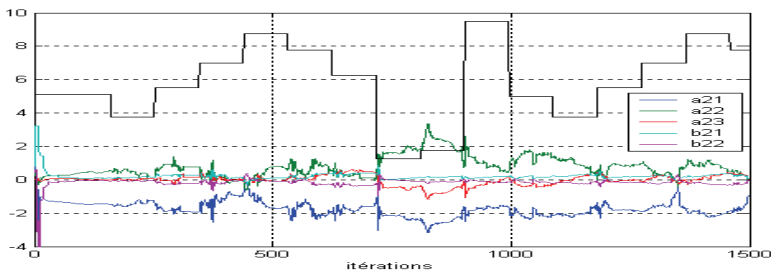

Fig. 7. Humid duct model estimated parameters

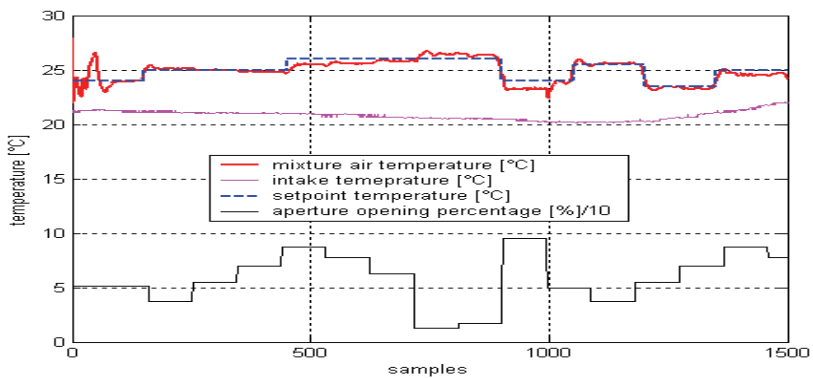

Fig. 8. IAGPC of the air mixture duct temperature

4.2 Direct strategy

Concerning the estimator algorithm, the sub-controllers parameter vectors were initialized by the nominal controller based on the nominal sub-model corresponding to 10% of aperture opening. The covariance matrix $F(0) = 10^5$, with a fixed forgetting factor, was $\eta = 0.96$. For the GPC algorithm controller, the control-weighting factor $\lambda = 0.97$, the minimum prediction horizon was fixed at a value $N_1 = d = 1$, and the maximum prediction horizon $N_2 = 3$, with a control horizon $N_u = 1$.

Good control performance is also obtained with the DAGPC for different setpoint values. The temperature ducts are closed to the setpoints in figures 9 and 10. The figures show a generally efficient disturbance rejection. Compared to the previous strategy, both ducts are sensitive to abrupt and significant changes in aperture position.

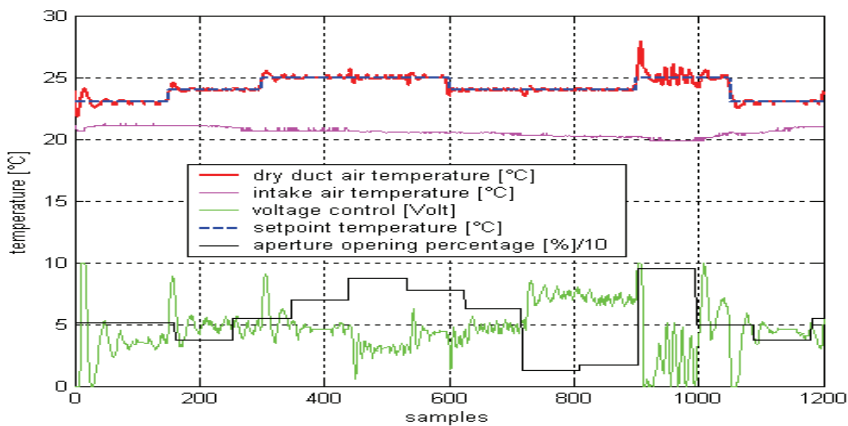

Fig. 9. DAGPC of the air dry duct temperature

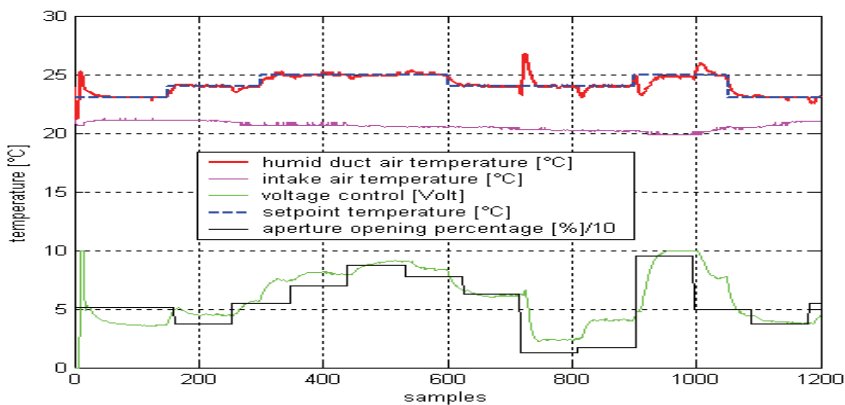

Fig. 10. DAGPC of the air humid duct temperature

The control strategy robustness may be observed, through temperature overshoots rejection. This type of disturbance is caused by the aperture commutation (operating point system variations) which in reality affects the air rate flow variation. At 900 th sampling time in figure 11, the overshoots presented by the humid duct air temperature response result from the abrupt aperture opening commutation, which introduces a performance error and, consequently, instantaneous closed loop instability between the 900 th and the 1000 th sampling time. These can be explained by the necessary time to update the parameter controllers, when the local controllers are trying to maintain the nominal closed loop performances index, in spite of parametric system variations.

In figure 9, air temperature fluctuations appear between the 900 th and the 1000 th sample time, such as in figure 11, because during this window of time the dry duct was nearly open ($x\% = 90\%$), and it thus made a significant contribution to air mixing.

To sum up, the air mixture temperature setpoints are guaranteed indirectly as consequence of the accuracy of the two temperatures at the upstream ducts in figure 11, showing the feasibility of the proposed humid air thermodynamic strategy.

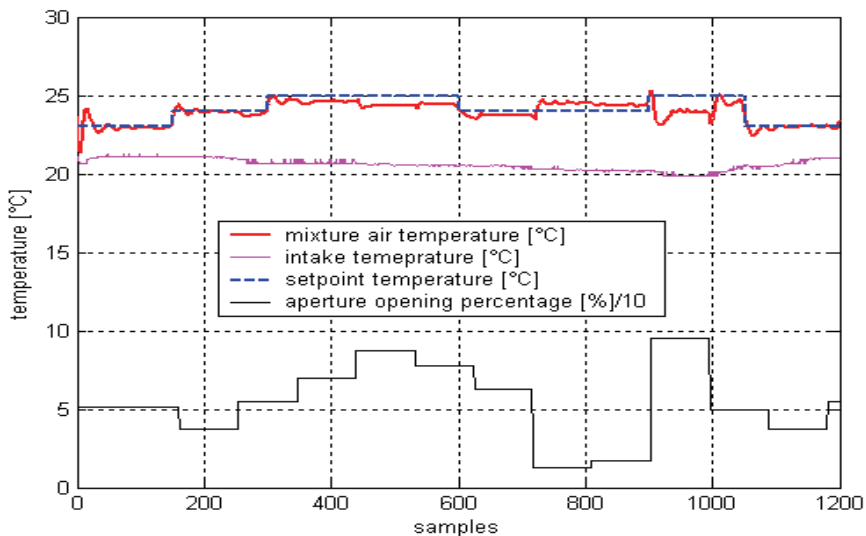

Fig. 11. DAGPC of the air mixture duct temperature

4.3 Humidity control

According to the air humid diagram (figure 1), the cascade strategy applied to the temperature and the relative humidity was intended to decouple these variables. This implies taking care of that relative humidity and temperature set points do not vary simultaneously. In order to validate the air conditioning output relative humidity, the nonlinear function between air and aperture position (Tawegoum et al.,2006b), combined with equation 1 and the relationship between absolute and relative humidity were used to defined the equivalent relative humidity set points.

Figure 12 illustrates the behaviour of relative air humidity in the mixing zone. It may be observed that, with little variation in the aperture position, the measurements are closed to

the set points. As the dynamics of the relative humidity are lower compared to those of the aperture, when the set point values vary permanently or vary abruptly, the tracking performances are too slow. Apart from these cases, one may consider the control to be good in a relative humidity range of between 75% and 95% since the errors remain in the standard deviation of the relative humidity sensors used.

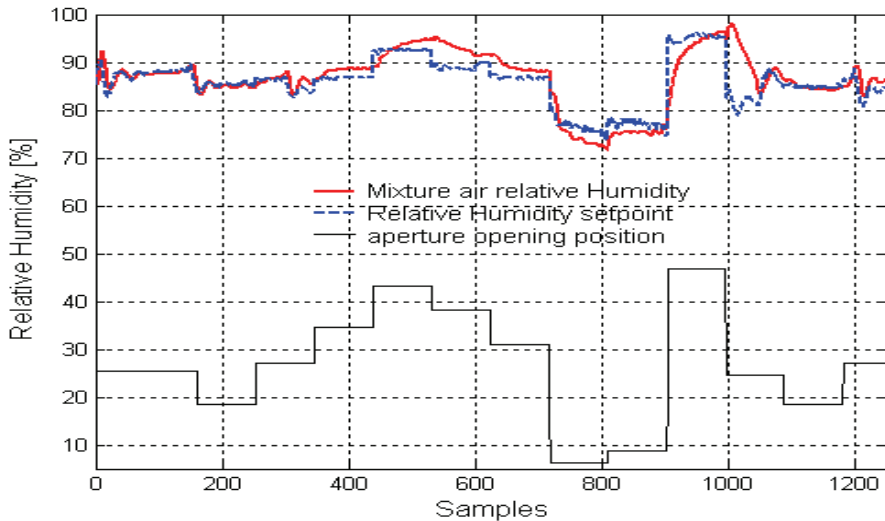

Fig. 12. Relative humidity of the mixture air

5. Conclusion

We have proposed a decentralized control scheme for the temperature and relative humidity control of a complex air conditioning unit. A local controller based on adaptive generalized predictive control theory has been designed for manipulating each sub-system with the objective of ensuring the setpoint temperature at the air mixture output under external and internal disturbances. The adaptive direct and indirect approaches proved to be good in both tracking and regulation. For the dry duct, the IAGPC also cancelled parametric variations, while for the humid duct both IAGPC and DAGPC reacted slowly to significant and abrupt variations. This is probably due to the time constant of the humid duct and to complex phenomena of mass and heat transfer between water and air, which takes place in the humid duct. These transfers also occur in the relative humidity in the mixing zone.

The close loop stability could be improved by taking into account a supervision level. Tracking performance may be enhanced by including the relative humidity dynamics in the control.

6. Acknowledgment

The authors would like to express their gratitude to Alain Travers for his valuable technical assistance.

7. References

- Albright, Gates R.S; Aravantis, K.G & Drysdale, A.E. (2001). Environment Control for Plants on Earth and Space, *IEEE Control Systems Magazine*, October 2001, pp. 28-47.
- Arguello-Serrano B. & Vélez-Reye M. (1999). Non linear control of heating, ventilating, and air conditioning system with thermal load estimation, *IEEE Transactions on Control Systems Technology*, vol. 7, No. 1, January, pp. 56-63.
- Bitmead, R. R.; Gevers, M. & Wertz, V. (1990). Adaptive Optimal Control, The thinking Man's GPC, Prentice-Hall, New York.
- Buchholz, M.; Buchholz, P.; Jochum, P.; Zaragoza, G. & Pérez-Parra, J. (2006). Temperature and humidity control in the watery greenhouse, *Proceedings International Symposium on Greenhouse Cooling*, Almeria-Spain, April 2006, pp. 401-407.
- Camacho, E. F. & Bordons, C. (2002). Model predictive control, *Advanced textbooks in control and signal processing*, Springer 2nd Edition.
- Chraïbi, A.; Makhlof, S. & Jaffrin, A. (1995). Refroidissement évaporatif de l'air des serres, *Journal de Physique*, n°III. Juillet 1995.
- Clarke, D.W. (1988). Application of generalized predictive control to industrial process, *IEEE Control Magazine*, N° 8, pp. 49-55.
- Clarke, D.W. ; Mohtadi, C. & Tuffs, P.S. (1987). Generalized predictive control- part I. The basic algorithm, *Automatica*, Vol 23, N°2, pp. 137-148.
- Clarke, D.W. ; Mohtadi, C. & Tuffs, P.S. (1987). Generalized predictive control- part II. Extensions and interpretations, *Automatica*, vol 23 N°2, pp. 149-160.
- Corrêa, N.A.; Corrêa, R.G. & Freire, J.T. (2000). Adaptive control of paste drying in spouted bed using the GPC algorithm, *Brazilian Journal of Chemical Engineering*, Sao Paulo dic, vol.17, N°4, pp.1-7.
- Cunha, J.B. & Oliveira, J.P.M. (2003). Optimal management of greenhouse environments, *Proceedings of EFITA Conference*, Debrecem, Hungary, 2003, pp. 559-564.
- Dion, J.M.; Dugard, L.; Franco, A.; Nguyen Minh Tri & Rey, D. (1991). Mimo adaptive constrained predictive control case study : an environmental test chamber, *Automatica*, vol 27, N°4, pp.611-626.
- Dumur, D. ; Boucher, P. ; Murphy, K.M & Déqué F. (1997). On Predictive Controller Design for Comfort Control in Single Residential Housing, *Proceedings of ,ECC'97*, juillet 1997, pp. 109-114.
- Filataov, N.M. & Unbedhauen, H. (2004). *Adaptive Dual Control: Theory and Applications*, Springer.
- Hanan J.J. (1997). *Greenhouse: advanced technology for protected horticulture*, Chapter 4, pp. 236-260.
- Jones, P. ; Jones, J.W. ; Allen, L.H. & Mishve, J.W. (1984). Dynamic computer control of closed environmental plant growth chambers, Design and Verification. *Transaction of ASAE. (American Society of Agricultural Engineers)*, pp. 879-888.
- Kittas, C.; Bartzanas, T. & Jaffarin, A. (2003). Temperature gradient in a partially shaded large greenhouse equipped with evaporative cooling pads, *Biosystems Engineering*, vol 85, N° 1, pp. 87-94.
- Landau, I.D. & Dugard, L. (1986). *Commande adaptative aspects pratiques et théoriques*, J. Masson, Ed. Paris, pp. 1-81.
- Ljung, L. (1999). *System identification : Theory for the user*, Prentice Hall.

- M'ssad, M. & Chebassier, J. (1992). Commande adaptative des systèmes, *Techniques de l'ingénieur*, vol. 7426, pp. 1-25.
- Montero, J.J.; Anton, A.; Beil, C. & Franquet, A. (1994). Cooling of greenhouses with compressed air fogging nozzles, *Acta Horticulturae*, N°281, pp. 199-209.
- Nybrant, T.G. (1989). Modelling and adaptive control of concurrent flow dryers, *Computers and Electronics in Agriculture*, vol 3, pp. 243-253.
- Rafilamanana, A.; Cabassud, A.; LeLann, M. V. & Casamatta, G. (1992). Adaptive control of a multipurpose and flexible semi-batch pilot plant reactor, *Comp. Chem. Eng.* Vol 16 N°9, pp.837-848.
- Ramond, E.; Rumur, D. & Boucher, P. (1998). A direct adaptive generalized predictive control structure : Application to a flexible structures, *Proceedings of IFAC symposium on Adaptive system in control and signal processing*, August, Glasgow, Scotland, pp.351-356.
- Riadi, R.; Tawegoum, R.; Rachid, A. & Chassériaux, G. (2006). Modeling and Identification of a Passive Air-Conditioning Unit using the Operating Dependent Parameters-Structure, *Proceedings of CESA-2006: Computational Engineering in Systems Application Conference*, Beijing, Chine-4-6 Octobre 2006, pp. 1485-1491.
- Riadi, R.; Tawegoum, R.; Rachid, A. & Chassériaux, G. (2007). Dencentralized temperature indirect adaptive predictive control of a passive air conditioning unit. *Proceedings of the 46th IEEE Conference on Decision and Control*, New Orleans, LA, USA, Dec 12-14, 2007, pp 1808-1813
- Richalet, J. ; Rault, A. ; Testud J. & Papon J. (1978). Model predictive heuristic control: Applications to industrial processes, *Automatica*, 1978, pp.413-428.
- Sethi, V.P. & Sharma, S.K. (2007a). Experimental and economic study of a greenhouse thermal control system using aquifer water, *Energy Conversion and Management*, vol 48, N° 1, pp. 306-319.
- Sethi, V.P. & Sharma, S.K. (2007b). Thermal modeling of a greenhouse integrated to an acquifer coupled cavity flow heat exchanger system, *Solar Energy*, vol 81, N°6 pp. 723-741.
- Sethi, V.P. & Sharma, S.K. (2007c). Survey of cooling technologies for worldwide agricultural greenhouse applications, *Solar Energy*, N° 81, pp. 1447-1459.
- Tawegoum, R.; Bournet, P.E; Arnould, J.; Riadi, R. & Chassériaux, G. (2006b). Numerical investigation of an air conditioning unit to manage inside greenhouse air temperature and relative humidity, *Proceedings International Symposium on Greenhouse Cooling*, Almeria-Spain, April 2006, pp. 115-122.
- Tawegoum, R.; Teixeira, R. & Chassériaux, G. (2006a). Simulation of humidity control and temperature tracking in a growth chamber using a passive air conditioning unit, *Control Engineering Practice Journal*, 2006, vol 14/ N° 8, pp. 853-861.
- Wang, W. & Henrisen, R. (1993). Direct adaptive generalized predictive control, *IEEE Transaction on Modelling, Identification and Control*, vol 14, pp.181-191.
- Wang, W. & Henrisen, R. (1994). A direct adaptive generalized predictive control, *IEEE Transaction on Modelling, Identification and Control*, vol 15, pp.23-32.
- Willis, D.H. & Peet, M.M. (2000). Intermittent application of water to an externally mounted greenhouse shade cloth to modify cooling performance, *Transactions of ASAE*, vol 43, N° 5, pp. 1247-1252.

Young, P.C. & Lees, M.J. (1994). Simplicity out of complexity in glasshouse climate modelling, *Proceedings of 2nd IFAC/ISHS Workshop on Mathematical an Control Application in agriculture and Horticulture*, 12-15 september 1994, Silsoe, United kingdom, Acta Horticulturae N°406, pp.15-28.



Frontiers in Robotics, Automation and Control

Edited by Alexander Zemliak

ISBN 978-953-7619-17-6

Hard cover, 450 pages

Publisher InTech

Published online 01, October, 2008

Published in print edition October, 2008

This book includes 23 chapters introducing basic research, advanced developments and applications. The book covers topics such as modeling and practical realization of robotic control for different applications, researching of the problems of stability and robustness, automation in algorithm and program developments with application in speech signal processing and linguistic research, system's applied control, computations, and control theory application in mechanics and electronics.

How to reference

In order to correctly reference this scholarly work, feel free to copy and paste the following:

Rousseau Tawegoum, Riad Riadi, Ahmed Rachid and Gerard Chasseriaux (2008). Adaptive GPC Structures for Temperature and Relative Humidity Control of a Nonlinear Passive Air Conditioning Unit, *Frontiers in Robotics, Automation and Control*, Alexander Zemliak (Ed.), ISBN: 978-953-7619-17-6, InTech, Available from: http://www.intechopen.com/books/frontiers_in_robotics_automation_and_control/adaptive_gpc_structures_for_temperature_and_relative_humidity_control_of_a_nonlinear_passive_air_con

INTECH

open science | open minds

InTech Europe

University Campus STeP Ri
Slavka Krautzeka 83/A
51000 Rijeka, Croatia
Phone: +385 (51) 770 447
Fax: +385 (51) 686 166
www.intechopen.com

InTech China

Unit 405, Office Block, Hotel Equatorial Shanghai
No.65, Yan An Road (West), Shanghai, 200040, China
中国上海市延安西路65号上海国际贵都大饭店办公楼405单元
Phone: +86-21-62489820
Fax: +86-21-62489821